

# CE-046

## 46 kV CURRENT TRANSFORMER



OUTDOOR  
60 Hertz

ARTECHE CE series are dry type outdoor service top-core current transformers. The core is encapsulated with Type B epoxy resin which provides excellent internal dielectric properties and mechanical strength. The external layer of Cycloaliphatic Epoxy Resin (CEP) provides resistance to ultraviolet rays and the effects of tracking and erosion on the exterior of the transformer ensuring a long mechanical and electrical life. The transformer is maintenance free.

The external layer can be manufactured with Hydrophobic Cycloaliphatic Epoxy Resin (HCEP) which improves service life expectancy due to its improved tracking and erosion resistance. HCEP additionally increases the transformer's weatherability and offers better performance in heavily polluted environments.

The core is built with high permeability grain oriented silicon steel laminations for low losses. The windings are copper wire with copper plate double isolation. The concentric distribution of the coils prevents magnetic flux leakage, achieving greater accuracy and higher capacity to withstand mechanical stresses in adverse operating conditions. The cores and windings are located in the upper part of the transformer. This head is coated with a conductive layer, which provides an adequate electric field control.

Partial Discharge measurements exceed the IEEE, CAN/CSA and IEC requirements.

### Mechanical characteristics

Insulation Material	Colors	Weight (lbs.)	Creepage distance (in)	Strike distance (in)
Resin	Gray*	595	75.2	22

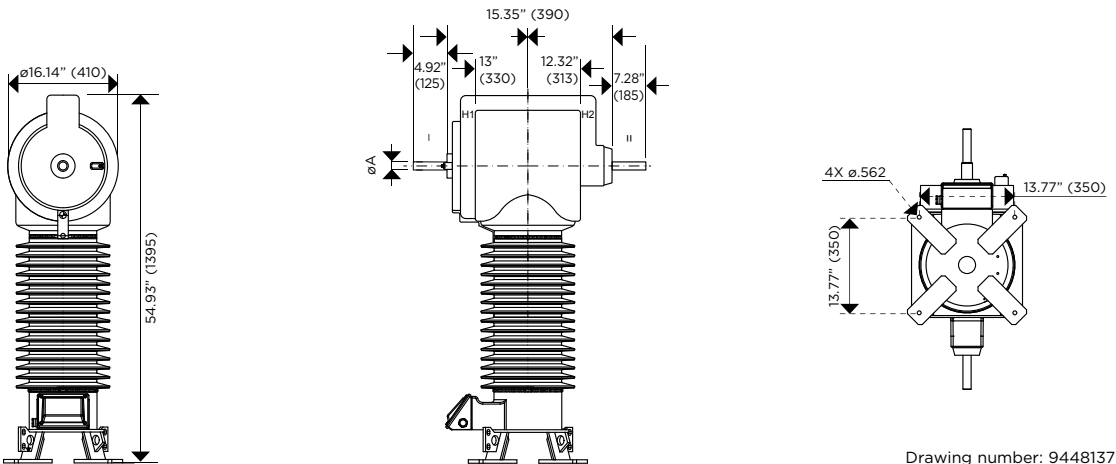

Drawing number: 9448137

CONNECTIONS	PRIMARY TERMINAL	GROUND CONNECTOR	SECONDARY TERMINAL	MARKING (Single Primary Ratio)
	<p>Type: PM30MCO-1-4N-E Material: Aluminum</p>	<p>Type: LZ-500 Material: Copper Range: 4/OTRE-500MCM</p>	<p>Type: Hex screw Material: Steel</p>	

Approximate dimensions in inches (mm). \* Brown color available upon request.

# CE-046

## 46 kV CURRENT TRANSFORMER

### Electrical characteristics

Code (CEP)	Code (HCEP)	Current Ratio (Primary: Secondary) (A)	Continuous Thermal Current Rating Factor @ 30°C	Short-time Thermal Current (kA/1s)	Short-time Mechanical Current (kA <sub>peak</sub> )	IEEE Metering Accuracy	Relay Accuracy	Nominal Voltage System (kV)	BIL (kV)	Power-Frequency Withstand Voltage (1 min)	
										Primary & Secondary (kV <sub>rms</sub> )	Secondary Winding (kV <sub>rms</sub> )
756162005	756160000-H	25/50:5	3.0/2.0	5	9.5	0.3B-1.8/0.3B1.8	T200/T400	46	250	95	2.5
756162006	756160001-H	30/60:5	3.0/2.0	6	11.4	0.3B-1.8/0.3B1.8	T200/T400	46	250	95	2.5
756162010	756160002-H	50/100:5	3.0/2.0	10	19	0.3B-1.8/0.3B1.8	T200/T400	46	250	95	2.5
756162015	756160003-H	75/150:5	3.0/2.0	15	28.5	0.3B-1.8/0.3B1.8	T200/T400	46	250	95	2.5
756162020	756160004-H	100/200:5	3.0/2.0	20	38	0.3B-1.8/0.3B1.8	T200/T400	46	250	95	2.5
756162030	756160005-H	150/300:5	3.0/2.0	30	57	0.3B-1.8/0.3B1.8	T200/T400	46	250	95	2.5
756162040	756160006-H	200/400:5	3.0/2.0	40	76	0.3B-1.8/0.3B1.8	T200/T400	46	250	95	2.5
756162060	756160007-H	300/600:5	3.0/2.0	60	86.7	0.3B-1.8/0.3B1.8	T200/T400	46	250	95	2.5
756162080	756160008-H	400/800:5	3.0/2.0	60	114	0.3B-1.8/0.3B1.8	T200/T400	46	250	95	2.5
756162100	756160009-H	500/1000:5	3.0/1.5	75	142.5	0.3B-1.8/0.3B1.8	T200/T400	46	250	95	2.5
756162120	756160010-H	600/1200:5	3.0/1.5	90	171	0.3B-1.8/0.3B1.8	T200/T400	46	250	95	2.5
756162150	756160011-H	750/1500:5	3.0/1.5	90	171	0.3B-1.8/0.3B1.8	T200/T400	46	250	95	2.5
756162200	756160012-H	1000/2000:5	2.0/1.5	90	171	0.3B-1.8/0.3B1.8	T400/T800	46	250	95	2.5
756162300	756160013-H	1500/3000:5	2.0/1.0	90	171	0.3B-1.8/0.3B1.8	T400/T800	46	250	95	2.5
<b>High Accuracy Extended Range</b> 1% nominal current to Rating Factor											
756166040	756160030-H	200:5	1.5	16	40	0.15 B-1.8	-	46	250	95	2.5
756166120	756160031-H	600:5	1.5	48	120	0.15 B-1.8	-	46	250	95	2.5
756166200	756160032-H	1000:5	1.5	50	125	0.15 B-1.8	-	46	250	95	2.5
756166240	756160033-H	1200:5	1.5	96	240	0.15 B-1.8	-	46	250	95	2.5

Additional ratings available upon request.

### Notes:

.....

.....

.....

.....

.....

.....

.....

.....

.....

.....

.....

.....

.....

.....

.....

.....

.....

.....

.....

.....

.....

.....

.....

.....

.....